



DIAL Atmospheric Profiler DA10



Vaisala DIAL Atmospheric Profiler DA10 is a high-performance differential absorption lidar (DIAL) instrument for enhanced severe weather forecasting and climate modeling with advanced, real-time water vapor profiles. DA10 offers continuous and unattended real-time water vapor profiling for operational observation networks.

Continuous data for forecasting and modeling

DA10 is an ideal instrument for weather nowcasting, forecasting, climate modeling, and atmospheric research. Because of continuous water vapor mixing ratio profiles, it is particularly well suited for severe weather forecasting and nowcasting.

DA10 measures the water vapor content in the atmosphere from low altitudes up to the top of the boundary layer or cloud base layer - whichever is lower. The advanced real-time water vapor profiles can be used as input to severe weather nowcasting and, for example, for the possible detection of atmospheric rivers. The measurement data is continuous, making DA10 an ideal solution for operational observation networks.

Advanced DIAL technology and optics

DA10 is essentially a ceilometer and a water vapor profiler combined. It provides cloud height information and real-time high-quality water vapor profiling data, as well as atmospheric profiles such as the attenuated backscatter profile.

The instrument uses 2 wavelengths of a near-infrared laser source and has 2 measurement units, with telescopes for far-range and near-range measurements. This together with the single-lens technology enables optimum performance over the full measurement range.

Portable and versatile netCDF data

The measurement data is available in the universal and accessible netCDF format. This allows for integration to various types of systems, but also sharing of files across organizations. The netCDF data includes both measurement data and monitoring data. This makes the data easily available for numerical weather prediction (NWP) models.

Uninterrupted autonomous operation

Vaisala instruments are made to perform in extreme weather conditions, and DA10 is no exception. The optics, electronics, and powering components are housed in a weatherproof cabinet, and have been thoroughly tested to ensure operation in demanding conditions.

DA10 is an eye-safe instrument with modern communication and network capabilities. The integrated security software keeps your instrument and data safe.

The instrument operates unattended, with extensive self-diagnostics and embedded fault analysis minimizing downtime. The monitoring data is available to network operators remotely. The need for site visits is minimal because the instrument does not need field calibration or regular maintenance. These contribute to the overall low cost of ownership.

Features

- Water vapor profiles up to 4 km (13 000 ft)
- Attenuated backscatter profiles up to 18 km (59 000 ft)
- Designed to support nowcasting, forecasting, climate modeling, and atmospheric research
- Improved signal-to-noise ratio (SNR) for enhanced atmospheric profiles
- Uses single-lens technology for optimum performance
- Excellent detection at low altitudes
- Measurement data in netCDF format
- Unattended, autonomous 24/7 operation
- Remote access, monitoring, and self-diagnostics

Technical data

Measurements

Atmospheric profiles	Water vapor mixing ratio profile in g/kg Attenuated backscatter profile Uncertainty for water vapor mixing ratio
Atmospheric parameters	Cloud base heights (up to 5 layers) ¹⁾ Cloud penetration depth or cloud thickness ¹⁾ Precipitation/fog detection ¹⁾ Sky condition ¹⁾ Surface PTU (pressure, temperature, and humidity measured by WXT534)

¹⁾ Available later.

Measurement performance

Measurement range accuracy against hard target	±5 m (16 ft 5 in)
Water vapor profiles	
Measurement range	50–4000 m (164–13 000 ft) ¹⁾
Reporting time resolution	1 min
Reporting height resolution	9.6 m (31 ft 6 in)
Averaging time	20 min ²⁾
Attenuated backscatter profiles	
Measurement range	0–18 000 m (0–59 000 ft)
Reporting time resolution	1 min
Reporting height resolution	4.8 m (15 ft 9 in)

¹⁾ 4000 m (13 000 ft) or up to cloud base or top of boundary layer.

²⁾ 10–60 min averaging time available later.

Operating environment

Operating environment	Outdoor use
Operating temperature	–50 ... +55 °C (–58 ... +131 °F) ¹⁾
Storage temperature	–50 ... +60 °C (–58 ... +140 °F)
Operating humidity	0–100 %RH
Maximum wind speed, without guy wires	30 m/s (67 mph)
Maximum wind speed, with guy wires	50 m/s (112 mph)
IP rating (when inside radiation shield, excluding window blower)	IP66

¹⁾ The power cable plug (EU and US version) is specified to a maximum of –40 °C (–40 °F).

Powering

Nominal voltage	120 V AC, 8 A 230 V AC, 4.2 A
Operating voltage	90–130 / 200–250 V AC
Overvoltage category	CAT II
Operating frequency	50–60 Hz
Power consumption	
With heating	Max. 960 W
Without heating	Max. 200 W

Data communication

Data interface	Ethernet (> 10 Mbit/s)
Maintenance interface	Ethernet
Message format	NetCDF
Status information	Internal monitoring data

Mechanical specifications

Dimensions (H × W × L)	1970 × 850 × 585 mm (77.56 × 33.46 × 22.03 in)
Weight, total	180 kg (400 lb)
Weight, radiation shield	90 kg (200 lb)
Weight, far-range measurement unit	60 kg (135 lb)
Weight, near-range measurement unit	25 kg (55 lb)
Material	Aluminum
Color	White (RAL9003)
Coating	Multi-layer coating to prevent environmental corrosion

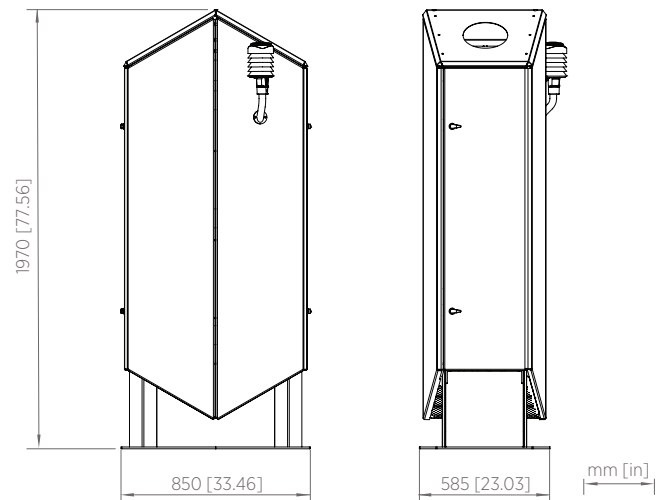

Compliance

EU directives and regulations	LVD, EMC, RoHS
EMC immunity	EN 61326-1, industrial environment
EMC emissions	CISPR 32 / EN 55032, Class B FCC part 15 B, Class B ICES-3 / NMB-3 (Class B)
Electrical safety	IEC/EN/UL/CSA-C22.2 61010-1
Eye safety ¹⁾	Class 1M laser product, IEC 60825-1:2014 (Edition 3.0) and EN 60825-1:2014 + A11:2021
Compliance marks	CE, China RoHS, FCC, ICES, RCM, UKCA

¹⁾ Complies with 21 CFR 1040.10 and 1040.11 except for conformance with IEC 60825-1 Ed. 3., as described in Laser Notice No. 56, dated May 8, 2019.

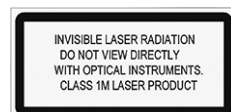

VAISALA

www.vaisala.com

Published by Vaisala | B212686EN-C © Vaisala 2024

All rights reserved. Any logos and/or product names are trademarks of Vaisala or its individual partners. Any reproduction, transfer, distribution or storage of information contained in this document is strictly prohibited. All specifications – technical included – are subject to change without notice.